

COMPONENTS: PREMTAPE HI-TACKTM PRIMER, PREMTAPE HI-TACKTM,
PREMIERTM MOULDING COMPOUND (OPTIONAL)

INSTRUCTIONS FOR USE

For the long term protection of above ground structural steelwork and pipe

SURFACE PREPARATION

Surfaces must first be thoroughly washed down with fresh water by hand scrubbing or preferably high pressure jet washing to remove all loose dirt and salt/chloride deposits. Heavy rust is removed by means of chipping hammers and scrapers. Power wire brush to remove all scale, rust and old flaking coatings to achieve a finish of St2 according to ISO 8501-1.

1. APPLICATION TO STEELWORK MEMBERS (EG ANGLES, RSJ'S)

PRIMING

After preparation brush apply a uniform coating of Premtape Hi-TackTM Primer at 5m²/litre over the entire metal surface. Leave for 15-30 minutes to dry until tacky to the touch.

APPLICATION

(i) I-beams are wrapped with a minimum of 4 separate lengths of tape. Angles, tees and channels are wrapped with a minimum of 2 separate lengths of tape. Choose widths of tape which permit overlaps of at least 25mm to be made in a downward direction on vertical surfaces and on the upper face on horizontal surfaces. Do not overlap the tape on the underside of horizontal surfaces (see diagrams below).

DIAGRAM OF THE CORRECT APPLICATION PROCEDURE

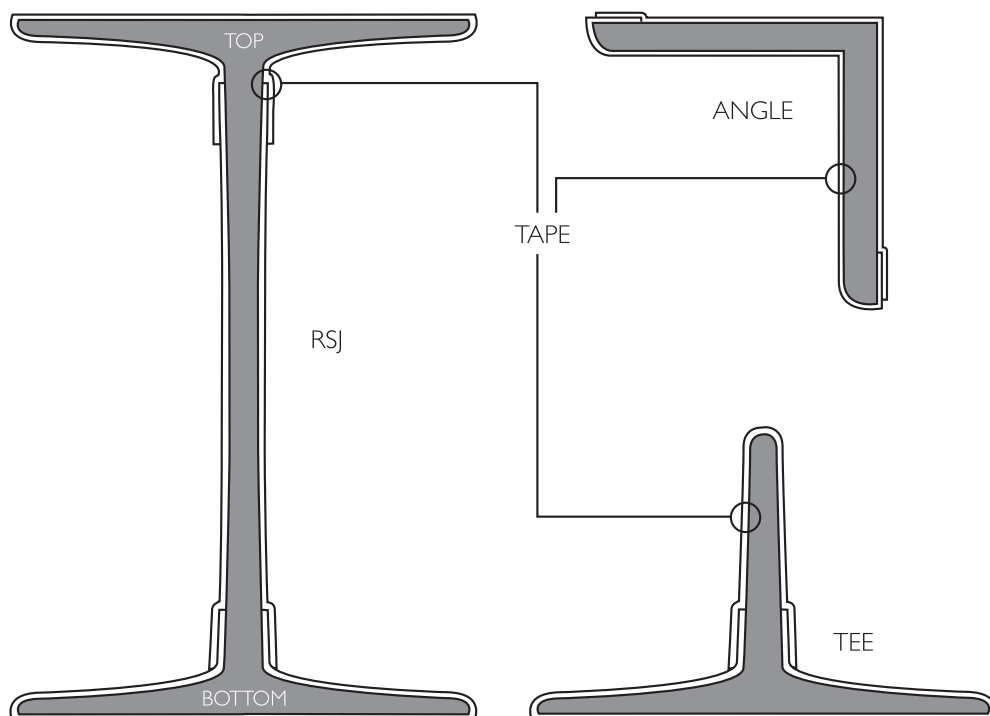

METHOD FOR WRAPPING STEELWORK

COMPONENTS: PREMTAPE HI-TACK™ PRIMER, PREMTAPE HI-TACK™, PREMIER™ MOULDING COMPOUND (OPTIONAL)

1. APPLICATION TO STEELWORK MEMBERS (EG ANGLES, RSJ'S) continued...

(ii) Precut up to 2m length of tape for application along the member or suitable lengths of 450mm wide tape to go around the member as diagram.

(iii) Apply the thickly coated side of the tape to the steelwork and smooth down thoroughly without stretching the

(iv) Apply the next strip of tape overlapping the first by 25mm and press down thoroughly at the overlaps. Ensure that the entire area of tape is smoothed down without air pockets under the tape, using hand or aluminium fluted roller. tape. At internal angles apply the tape to one face first and press well into the corner before pressing it down on the second face.

(v) At the rivet heads, nuts and bolts, etc make two cuts in the tape in the form of a cross over the rivet or bolt. Press the tape down thoroughly around the head and then place a small patch of tape to cover the rivet or bolt with at least 25mm overlap all around and smooth thoroughly. Premier™ Moulding Compound is recommended to fill any difficult void areas including the voids formed at the back angles.

(vi) Where steel angles or joists have corroded or sharp edges, apply a 50mm wide tape along the entire edge before applying the main protection.

(vii) On vertical members always start applying tape at the bottom and work up to ensure that overlaps will be in a downward direction.

(viii) Finally, inspect the whole structure smoothing down as necessary to ensure a neat appearance with all overlaps pressed down and no gaps or bare areas.

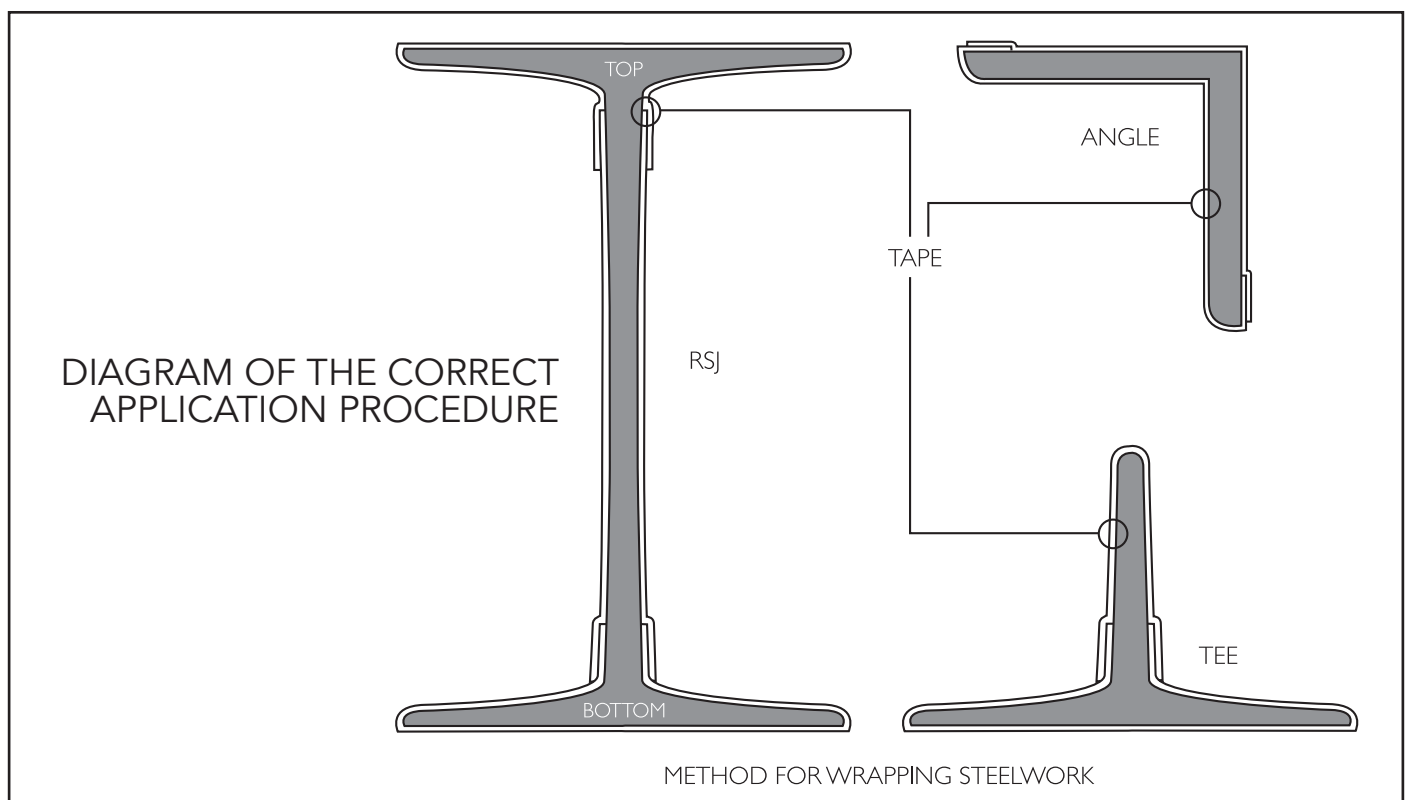

COMPONENTS: PREMTAPE HI-TACKTM PRIMER, PREMTAPE HI-TACKTM,
PREMIERTM MOULDING COMPOUND (OPTIONAL)

2. APPLICATION TO PIPEWORK AND TUBULAR STRUCTURES

PRIMING

After preparation brush apply a uniform coating of Premtape Hi-TackTM Primer at 5m²/litre over the entire metal surface. Leave for 15-30 minutes to dry until tacky to touch.

APPLICATION

- (i) Use PremierTM Moulding Compound to smooth the profile of any fittings to ensure that no voids can form under the tape wrap.
- (ii) Select as wide a width of tape as practical for ease of application. For pipes up to 300mm diameter, select the same width of tape as the pipe diameter. A maximum of 300mm wide tape is used for all diameters greater than 300mm.
- (iii) On vertical pipes start wrapping at the bottom and work up.
- (iv) Unwind about 300-500mm of tape and apply the inside of the roll to the pipe surface. Unroll the tape around the tubular section in a spiral, overlapping each turn by at least 25% of the tape width.
- (v) Apply sufficient tension to ensure good contact with the metal but do not overstretch the tape.
- (vi) Smooth down any folds or creases and press down all overlaps.

DIAGRAM OF THE CORRECT APPLICATION PROCEDURE

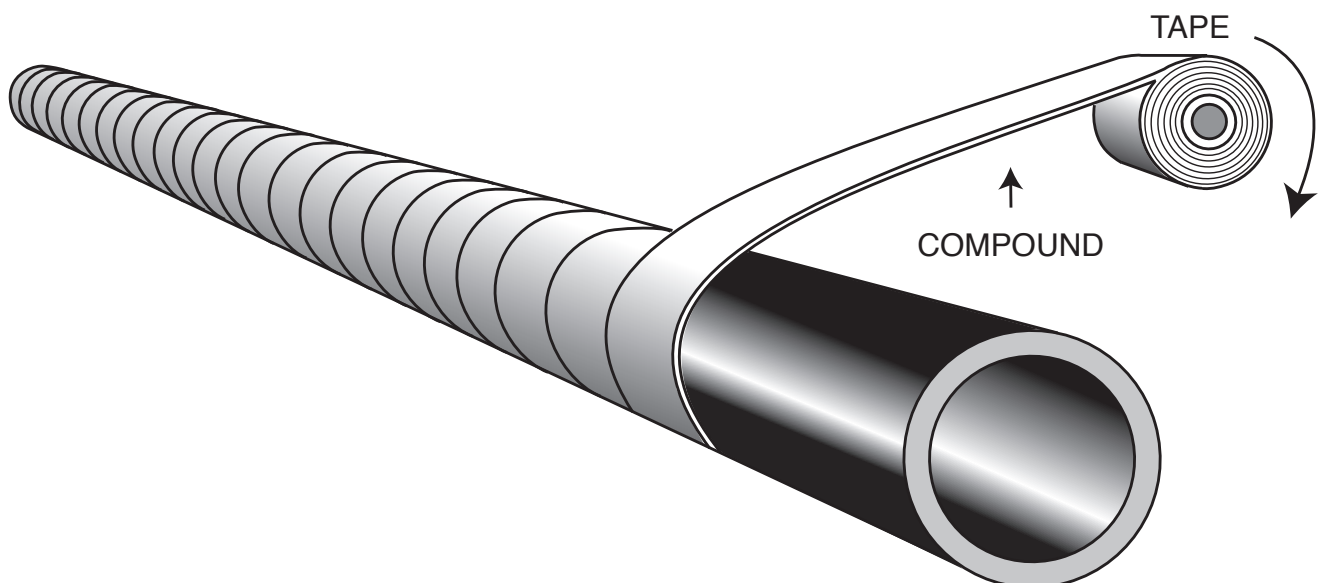

METHOD FOR WRAPPING PIPES AND TUBULAR STRUCTURES WITH PREMTAPE HI-TACK

COMPONENTS: PREMTAPE HI-TACKTM PRIMER, PREMTAPE HI-TACKTM,
PREMIERTM MOULDING COMPOUND (OPTIONAL)

INSTRUCTIONS FOR USE

INSPECTION

Visually inspect for correct overlap and absence of voids.

STORAGE:

Store in a cool, dry place.

TRANSPORT:

No special precautions necessary.

HANDLING:

Please refer to the Safety Data Sheet for instructions.

DISPOSAL:

Please do not discard waste material, including packaging, in the surrounding environment. Follow all relevant legislation for disposal.

IMPORTANT: Premier Coatings Ltd pursue a policy to develop and continually improve all of our products and therefore information given in this data sheet is intended as a general guide and does not constitute a warranty or specification. However, our sales personnel are committed to assisting the user in establishing the suitability of the product for its intended purpose and additional specific information is available on request. These Instructions may not cover all circumstances and must be read in conjunction with the project specifications. For further advice contact Premier Coatings Ltd.