

Field welded joints, also called girth welds, can be protected from corrosion by coating them with Viscotaq™ Viscowrap™ and an Outerwrap suitable for the service conditions of the pipeline. These systems meet the requirements of ISO 21809-3.

COMPOSITION

ViscotAQ™ is a unique viscous-elastic amorphous a-polar polyolefin for the protection against corrosion of underground and aboveground substrates.

The molecular chemistry of Viscotaq™ is unique and is designed in such a way that the viscosity gives it permanent wetting characteristics; forcing the material to flow into the pores and anomalies of the substrate. The elasticity of the product gives it the strength and feeling of a solid.

ViscotAQ™ always remains in a semi solid state, offers immediate adhesion without the need for primer, requires minimal surface preparation and forms a homogeneous, continuous, self-healing corrosion protection coating.



COMPONENTS

ViscotAQ Viscowrap™ is the primary corrosion prevention layer. The product is comprised of a Viscotaq compound supported by a mesh reinforcement and plastic backing. It is supplied in rolls or sheets for application directly to the exposed steel surface of the field joint and the factory/plant coating.

Premier™ PVC or PE Outerwrap provides mechanical protection and compression to the Viscotaq Viscowrap. The product is comprised of a tough PVC or PE tape coated with a pressure sensitive adhesive. The PVC or PE Outerwrap is applied with tension to compress the Viscowrap and promote adhesion. Applied in a double layer it provides mechanical protection to the system during backfill and service.

Premier™ Glass Outerwrap (Optional) provides additional mechanical protection to the system. The product is comprised of a woven glass cloth, impregnated with a moisture cured polyurethane resin. Applied in a double layer with the addition of water, it will cure to form a very tough layer which provides mechanical protection to the system during backfill and service.

SURFACE PREPARATION

- The minimum requirement for surface preparation is ST2 / SSPC-SP2 (Hand Tool Clean) the preferable level of surface preparation is to ST3 / SSPC-SP3 (Power Tool Clean).
- The field joint must be free from dust, grease, and moisture.
- The factory/plant coating must be bevelled to an angle to approximately 45°.

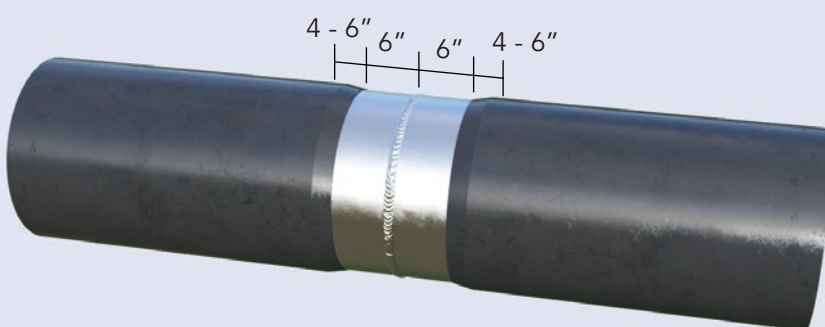
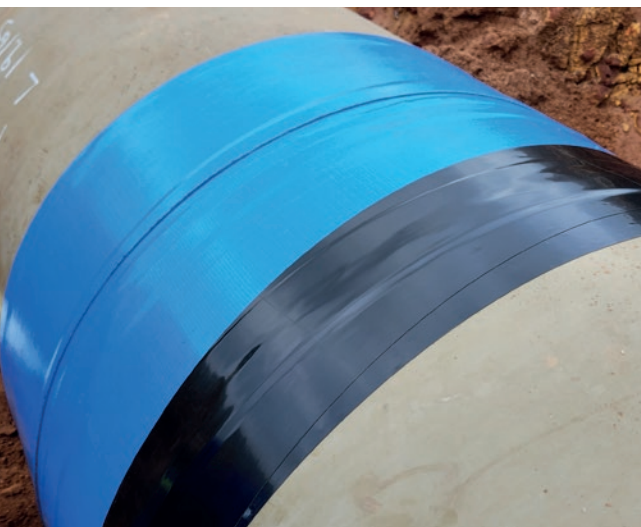

(Continued overleaf.)

VISCOTAQ™ FIELD JOINT COATING SYSTEM

APPLICATION

Application of Viscotaq™ Viscowrap™

Apply the Viscowrap to the field joint using either circumferential or spiral wrapping. The Viscowrap shall extend onto the factory/plant coating. The size, dimensions and grade of ViscoWrap shall be provided in the APS.

Application of Premier™ PVC Tape or PE Outerwrap

Apply the Premier PVC or PE Outerwrap over the Viscowrap by spiral wrapping. The PVC or PE Outerwrap shall or shall not extend onto the factory/plant coating as instructed in the APS. The size and thickness of the PVC or PE Outerwrap shall be provided in the APS.

Application of Extra Mechanical Protection

If required apply the Premier Glass Outerwrap™ over the PVC or PE Outerwrap. The Premier Glass Outerwrap shall extend onto the factory/plant coating as instructed in the APS.

1. Application of first sheet of Viscowrap by circumferential wrapping.

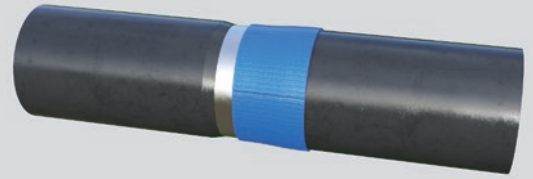

2. Application of second sheet of Viscowrap by circumferential wrapping.

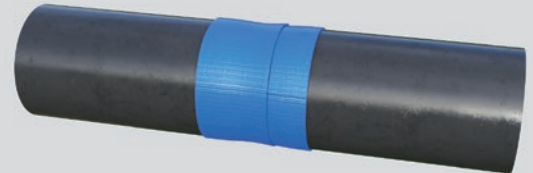

3. Application of Premier PVC or PE Outerwrap by spiral wrapping.

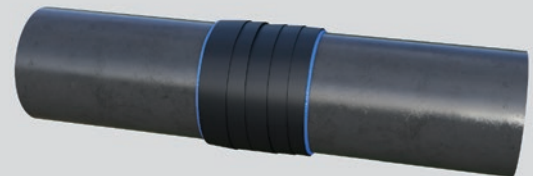

4. Application of Premier Glass Outerwrap by spiral wrapping.

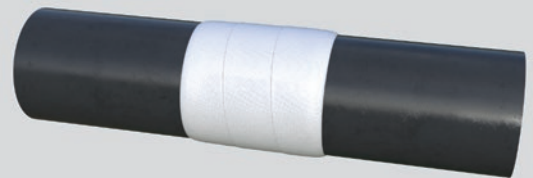

PUB No. 676.07.2024



PREMIER COATINGS LTD

TEL: +44 (0) 1233 770 663
EMAIL: enquiries@premiercoatings.com
WEB: www.premiercoatings.com

Headcorn Road, Smarden
Ashford, Kent TN27 8PJ
UNITED KINGDOM

